

■ Also available

**Cordless Portable Band Saw
PB002G**

Max. cutting capacity: 127 mm
Blade length: 1,140 mm
Net weight: 6.6 - 7.8 kg



■ Accessories

Band saw blade

Width : 13 mm
Thickness : 0.5 mm
Length : 835 mm

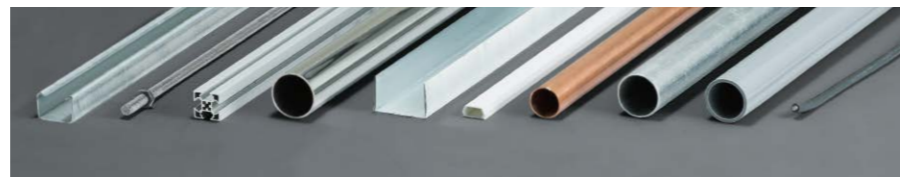

Part No.	Type	Width (mm)	No. of teeth per inch	Teeth shape	Application
B-40543	Bi-Metal (5pc.)	3 mm-6 mm	14	 Wave teeth	Plastics and non-ferrous metal. Mild steel, cast steel and cast iron. Hard steel and stainless steel.
B-40559		2 mm- 3 mm	18		
B-40565		less than 2 mm	24		

Stand set

Part No. 1917F0-6



Grip 36 set

Part No. 198043-5



Cutting wax

Part No. 191897-9



■ Charging Time

Model	Capacity	Fast Charging DC40RA	Standard DC40RC
*BL4020 191L29-0	2.0Ah	22 min	30 min
*BL4025 191B36-3	2.5Ah	28 min	38 min
*BL4040/F 1910N6-8	4.0Ah	45 min	67 min
BL4050F 191L47-8	5.0Ah	50 min	85 min
BL4080F/H 191X65-8/ 1916T7-4	8.0Ah	76 min	170 min

*1 Recommended battery

Cordless Portable Band Saw PB003G	
<ul style="list-style-type: none"> Variable Speed Brake Anti-restart function Constant Speed Built-in Job Light 	<p>Capacity Square: 66 x 66 mm (2-5/8 x 2-5/8"), Round: 66 mm (2-5/8")</p> <p>Blade speed 0 - 3.2 m/s</p> <p>Blade size Length: 835 mm (32-7/8"), Width: 13 mm (1/2") Thickness: 0.5 mm (1/64")</p> <p>Vibration level 1.4 m/s² (ENIEC62841-2-20, Mode: Cutting metal)</p> <p>Uncertainty (K) for Vibration 1.5 m/s² (ENIEC62841-2-20, Mode: Cutting metal)</p> <p>Sound pressure level 82 dB(A) (ENIEC62841-2-20)</p> <p>Sound power level 90 dB(A) (ENIEC62841-2-20)</p> <p>Uncertainty (K) for Noise 3 dB(A) (ENIEC62841-2-20)</p> <p>Dimensions (L x W x H) 392 x 175 x 244 mm (15-1/2 x 6-7/8 x 9-5/8")</p> <p>Battery BL4025</p> <p>Net weight 4.0 - 5.2 kg (8.8 - 11.5 lbs.)</p> <p>Battery BL4020 - BL4080F</p> <p>Standard Equipment : Band saw blade, Hex wrench, Grip, Battery, Charger, Hook</p>

The weight may differ depending on the attachment(s), including the battery cartridge. The lightest and heaviest combinations are shown in the table.
Items of standard equipment and specifications may vary by country or area.

Makita Singapore Pte Ltd

7, Changi South Street 3, Singapore 486348
Phone : +65-6546-8700 Fax : +65-6546-8711
Email : msgproductteam@makita.com.sg
Website : www.makita.com.sg
Facebook : www.facebook.com/MakitaSG



MakitaSG



VISIT OUR WEBSITE



DOWNLOAD LEAFLET

PRINTED IN SINGAPORE

**Powerful & Fast Cutting
for a wide range of materials**

Cutting speed
about **30%UP**

Cut Carbon steel pipe of 48.6 mm diameter with thickness of 3.7 mm using blade supplied with machine.
*Compared with our 18V model



Max. Cutting capacity
Round pipe

ø 66 mm

Square pipe
66 x 66 mm

Cutting speed about **30%UP**

Cut Carbon steel pipe of 48.6 mm diameter with thickness of 3.7 mm using blade supplied with machine.

*Compared with our 18V model



LED job light

A diffusion lens spreads light evenly, reducing blade shadows and making it easier to align the blade with the cutting line.



Max. cutting capacity
Round pipe
ø 66 mm
Square pipe
66 x 66 mm

Minimizes RPM drop under heavy load.



High-power Brushless motor

Constant speed control

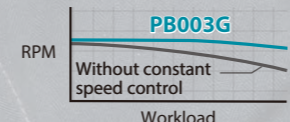

Work amount on a single full battery charge	
Carbon steel pipe ø48.6 x t 3.7 mm	Approx. 93 pcs Battery: BL4040F
Thin steel pipe ø38.1 x t 1.4 mm	Approx. 60 pcs Battery: BL4025
	Approx. 276 pcs Battery: BL4025

Ensures stable cutting when used with Stand Set

Cutting capacity
(with stand attached)

Round pipe: **ø 55 mm**
Square pipe: **55 x 55 mm**

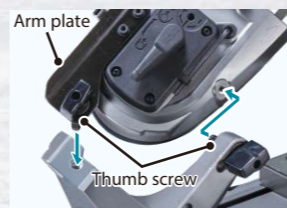

Easy Installation

Mount Arm plate* on PB003G, and you can secure the band saw to Stand easily with two Thumb screws* without tool.
* Supplied with Stand set

Stable clamping vise

The Vise assembly is designed to slant backward so that it can press the workpiece against both the Guide fence and Base of the stand at a time, providing secure and stable clamping.



Variable speed control by dial

Blade speed adjustable to match the material.



Dial	Blade Speed	Application
1 [Low]	1.3 m/s	Stainless steel, alloy steel, and other hard-to-cut materials
2	1.5 m/s	Steel materials (solid round bar, structural steel, thick steel pipe, etc.)
3	2.1 m/s	
4	2.5 m/s	
5	2.9 m/s	Steel materials (thin steel pipe, etc.)
6 [High]	3.2 m/s	

Easy positioning of stopper plate without tool

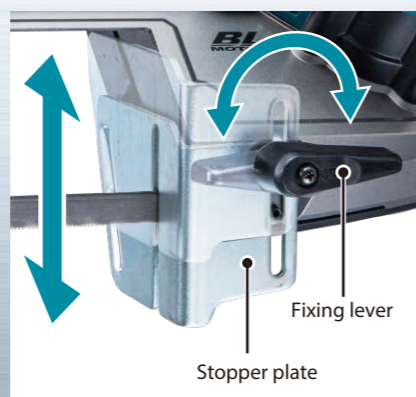

Easy installation / removal of blade

Exposed wheel design allows easy blade replacement.



Externally adjustable blade tracking

Easily adjustable using the supplied hex wrench.



Catch bracket

Designed to hit against workpiece in place of the tool body at the end of cutting process. It can protect the resin housing from scratches and damage.



Tool hook

Hangable on ladders, etc.



Water-resistance compatible with XPT

