



# Diagram / Parts List

**AT638**  
**AIR TACKER**



(SG) AT638 / AIR TACKER

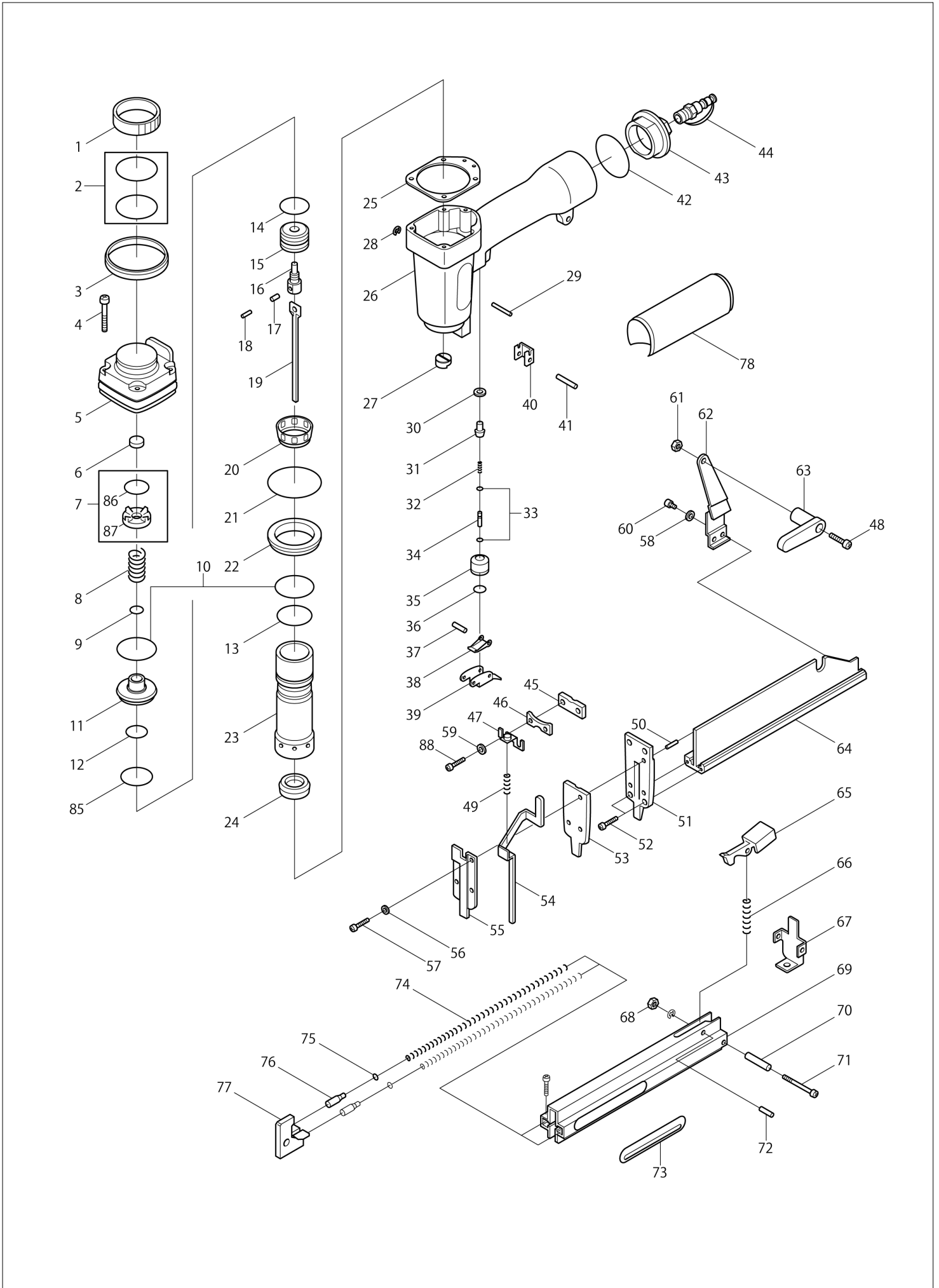

**SG****SINGAPORE****AT638 / AIR TACKER**

Item	Sub	Parts No.	Parts Description	Qty	I/C	E/C No.	Close No.	Remark
001		A0304-0301	EXHAUST VALVE COLLAR	1				
002		A0200-1581	O-RING 35.5X1.8	2				
003		A0204-0011	COVER GRIP	1				
004		A0000-0201	SCREW 5X35	4				
005		A0301-0171	EXHAUST COVER	1				
006		A0311-0121	AIR SEAL	1				
007		K0300-0671	EXHAUST VALVE ASS'Y	1				
008		A0100-0221	SPRING	1				
009		A0200-0231	O RING 9.8X2.4	1				
010		A0200-1041	O-RING 32 X 2.5	2				
011		A0308-0221	HEAD VALVE PISTION	1				
012		A0200-0251	O RING 13X3	1				
013		A0200-0601	O-RING 26.59 X 2.95	1				
014		A0200-0721	O-RING 22.9X2.7	1				
015		A0602-0181	PISTON HEAD	1			Y07422	
015-1		K0600-0471	PISTON SET	1	<	Y07422		
016		A0601-0011	DRIVER BLADE PIN	1			Y07422	
017		A0011-0051	OUTER SPRNG PN 4X10	1			Y07422	
018		A0011-0061	INNER SPRING PIN 2.5X10	1			Y07422	
019		A0600-0891	DRIVER BLADE	1			Y07422	
020		A0305-0081	SLEEVE RETAINER	1				
021		A0200-0271	O-RING 44.8X2.6	1				
022		A0800-0391	SPACER	1				
023		A0303-0182	CYLINDER	1				
024		A0309-0181	BUMPER	1				
025		A0205-0101	GASKET	1				
026		A0401-0221	BODY	1				
027		A0310-0121	NOZZLE	1				
028		A0005-0041	E-RING 2.5	2				
029		A0006-0291	STEP PIN 5X28	1				
030		A0505-0021	"SEAL, AIR"	1				
031		A0503-0091	TRIGGER VALVE HEAD	1				
032		A0104-0031	SPRING	1				
033		A0200-0431	O-RING 1.9X 1.2	2				
034		A0504-0061	TRIGGER VALVE STEM	1				
035		A0503-0061	TRIGGER VALVE GUIDE	1				
036		A0200-0331	O-RING 9.8X1.9	1				
037		A0011-0041	SPRING PIN 2 X 16	1				
038		A0501-0001	RELEASING BLADE	1				
039		A0500-0101	TRIGGER	1				
040		A0711-0891	BLOCK	1				
041		A0011-0161	SPRING PIN 3X24	2				
042		A0200-0281	O-RING 37.5X3.5	1				
043		A0306-0241	TAIL COVER	1				
044		B0300-3341	AIR PLUG WITH DUSTER	1				
045		A0800-0161	SPACER	1				
046		A0800-0231	SPACER	1				
047		A0719-0041	SPRING HOLDER	1				
048		A0000-0091	SCREW 5X20	1				
049		A0100-0211	COMPRESSION SPRING	1				
050		A0011-0271	SPRING PIN 1.5 X 10	1				
051		A0801-0571	DRIVER GUIDE	1				
052		A0001-0001	SCREW M4X18	2				
053		A0800-0341	SPACER	1				
054		A0711-0581	RELEASE CATCH	1				
055		A0801-1471	DRIVER GUIDE COVER	1				
056		A0000-0101	SCREW 5X22	2			Y07940	
056-1		A0005-0051	WASHER #4-0.9T	2	<	Y07940		
057		A0000-0231	SCREW M4X12	5				
058		A0005-0051	WASHER #4-0.9T	5				
059		A0005-0031	WASHER #5-1.1T	2				
060		A0000-0011	SCREW 4X8	2				
061		A0004-0021	NYLON NUT M5	1				
062		A0706-0051	SUPPORT	1				
063		A0316-0041	BELT HOOK	1				

Interchange  
O : Yes  
X : No  
< : the new part can be substituted for the current.  
> : the current part can be substituted for the new.  
S : Interchangeable as a set.

